

iQ-1000 ON/OFF

Remote Controlles Switch 230 VAC

230 VAC remote controlled switch, type iQ-1000 ON/OFF. It is suitable for single phase 230 VAC devices.

Provides 2 ON-OFF outputs. A version for 230 VAC rolling shutters is also available.

Basic Characteristics

- Max for each output 200W/230VAC
- Incorporated rolling coded RF receiver with two channels 433.92 MHz.
- 2 Outputs with latch. Each output is independent and switches state on round basis (OFF-ON-OFF-...) on each command received (through remote control only).
- Easy connection and remote control programming.
- Extremely compact. Size: 44x44x25 mm

Connection

On this example iQ-1000 ON/OFF is used to turn on / off 2 lamps (K1 K2). Each lamp is independent from one another. We can turn each one on or off independantly from the other.

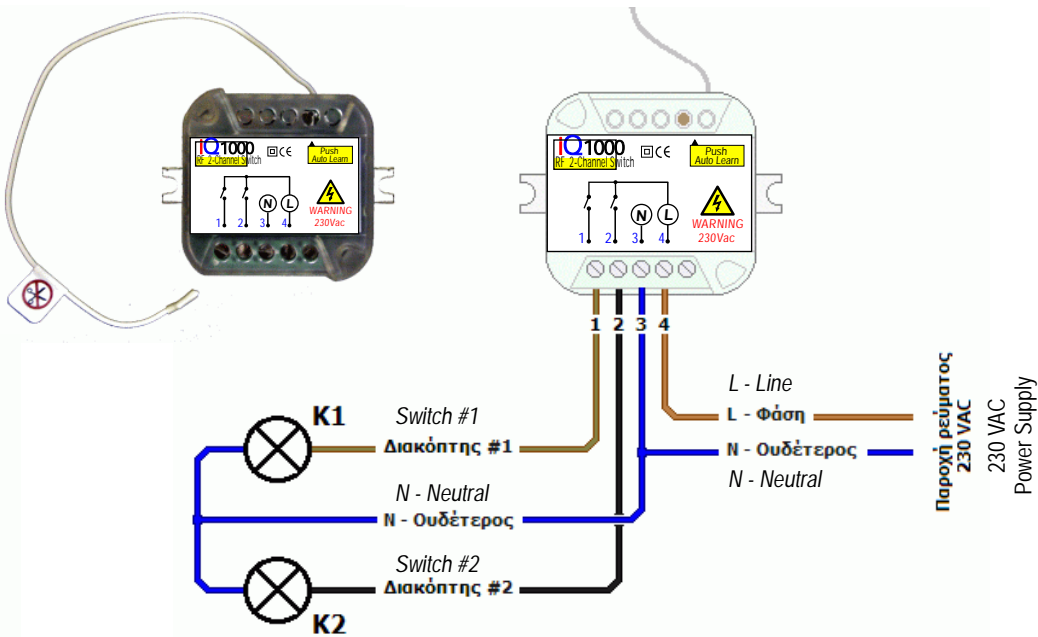
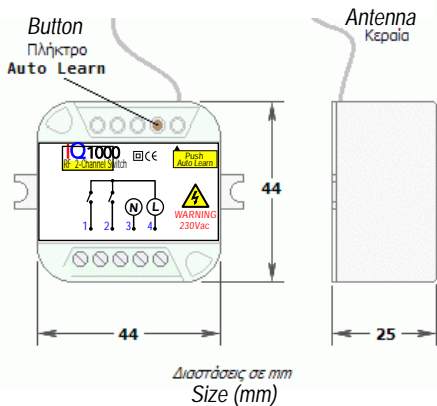

ATTENTION

The Product must be installed by qualified personnel who can carry out the installation operation strictly in compliance with safety rules. The device must not be used incorrectly or for any purposes other than the ones designed for. Before proceeding with the installation it is necessary to read the instruction manual carefully in order to avoid danger to either the users or the equipment. It is necessary to power the device using a 6A bipolar thermomagnetic switch equipped with a differential with an operating current of 0.03 A. Before carrying out any installation or maintenance operations turn off the power supply to the device with the bipolar switch. The equipment must not be tampered with or modified in any way. It is necessary to turn off the power supply to the equipment before installing it or opening the enclosure.

The manufacturer reserves the right to make changes to the product without prior notice. Therefore this manual may not correspond exactly to the product specifications.

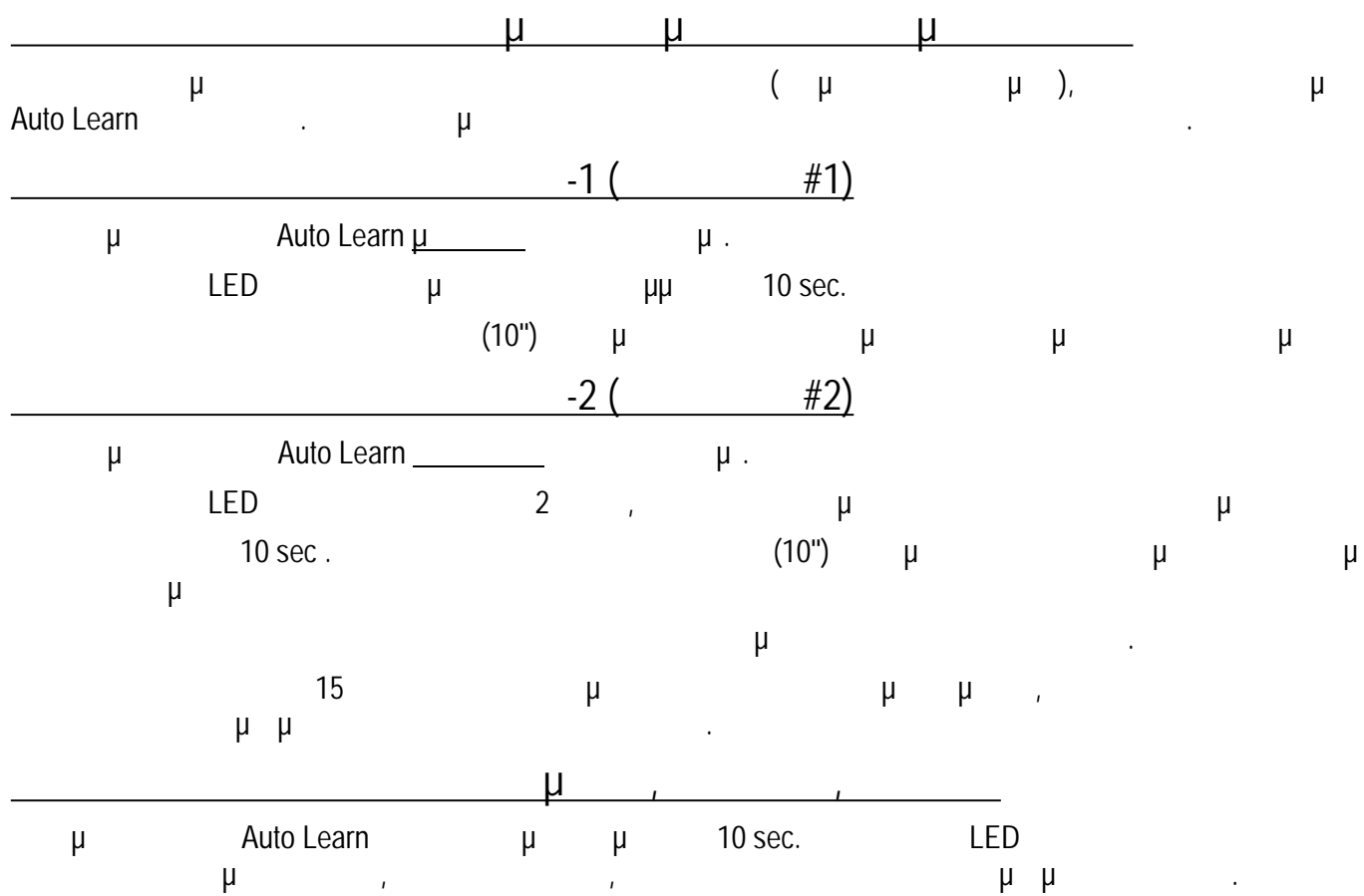

Storing compatible remote control to receiver

To begin the remote control programming procedure we will have to follow the instruction bellow which begin by pressing the Auto - Learn button on the upper right corner of the pcb.

Storing remote control for output - 1 (Switch #1)

- Press and release Auto Learn button ONCE.
- The receivers LED turns steadily on for 10 sec.
- During this time (10") we press the remote control we want to store.

Storing remote control for output - 2 (Switch #2)

- Press and release Auto Learn button TWICE.
- The receivers LED turns steadily on for 10 sec.
- During this time (10") we press the remote control we want to store.

To store additional remote controls we must repeat the procedure from the beginning.

If the receiver has already stored 15 remote controls and we store one more, the older one will be erased from memory and will be replaced from the new one.

Total erase off all stored remote controls

Press and hold Auto Learn button for 10 sec. The receivers LED starts blinking. All stored remote controls have been erased from the receivers memory.